

The CA25/30 family of vibratory rollers consists of the CA251/301, Std, D and PD.

These rollers are designed for efficient, high-capacity compaction of roads, airfields, dam constructions and similar applications and they effectively pack crushed stone, gravel, sand and clay. CA251/301 is the basic version described in these instructions.

Separate information is available on request concerning accessories or additional equipment.

Maintenance CA251/301

VIBRATORY ROLLER

M-10235-2 En

Diesel Engine:
Cummins 6BT 5.9
Deutz F6L 912

These instructions apply from
S/N*581*10251* and
S/N*582*10301*

P/N 11 19 59

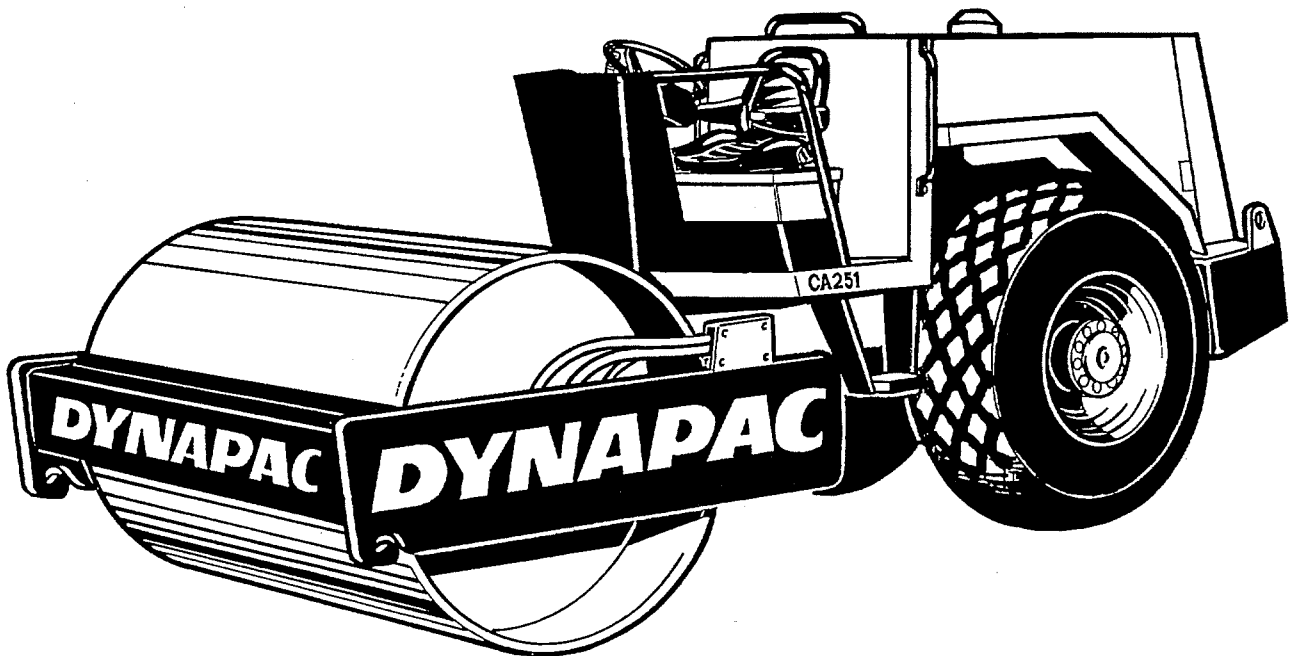

DYNAPAC

Dynapac Heavy Equipment AB

CONTENTS

| | Page |
|-----------------------------|------|
| Specifications, Symbols | 3 |
| Maintenance Schedule | 6 |
| Maintenance Measures: Daily | 10 |
| Weekly | 12 |
| Monthly | 16 |
| Every Six Months | 20 |
| Yearly | 22 |
| Special instructions | 25 |
| Electrical system | 25 |

CAUTION



READ ALL THE INSTRUCTIONS THOROUGHLY BEFORE CARRYING OUT ANY SERVICING OPERATIONS.

Proper care of the roller is essential to ensure satisfactory operation.

Keep the machine clean so that any leakage, loose bolts or loose connections can be easily detected.

Make a habit of inspecting the roller every day before starting up by checking all round and underneath the machine to detect any sign of leakage or other faults.

CAUTION



TAKE CARE OF THE ENVIRONMENT. Do not spill oil or fuel, or leave anything else that could be detrimental to the environment.

This manual contains directions for periodical servicing which should normally be carried out by the operator.

CAUTION



In addition, instructions in the manual provided by the engine manufacturer also apply. This is included in the product folder accompanying the roller.

SPECIFICATIONS, SYMBOLS

Always use well known high-quality lubricants from reputable suppliers. Servicing, that is otherwise correct, can be completely spoiled by the use of inferior lubricants.

Variants of the basic symbols shown below are also used but they too refer to the specified lubricant.



Engine oil, grade
Ambient temperature
-10°C to +50°C
(+14°F to +122°F)

API Service CD/SE
SAE 15W/40



Hydraulic fluid,
ambient temperature
-10°C to +40°C (+14°F to +104°F)
Ambient temperature
above +40°C (+104°F)

Shell Tellus Oil T68 or equivalent
Shell Tellus Oil T100 or equivalent



Gear lubricant, grade
Ambient temperature
-15°C to +40°C (+5°F to +104°F)
Ambient temperature
above +40°C (+104°F)

API, GL-5
SAE 80W/90 HD
Shell Spirax HD85W/140 or equivalent



Grease

Shell EP Grease 2 or equivalent



Fuel

See engine manual













Coolant,
50/50 mixture with water

Shell Anti Freeze 402 or equivalent

SPECIFICATIONS, SYMBOLS

Other symbols

| | | | |
|---|--|---|----------------------------|
|  | WARNING - Personal safety may be involved |  | Air cleaner |
|  | CAUTION - Damage to component or machine |  | Engine, oil level |
|  | Hydraulic filter |  | Engine, oil filter |
|  | Transmission, oil level |  | Hydraulic reservoir, level |
|  | Tyre pressure |  | Coolant, level |
| | |  | Lubricating oil |

| Tightening torque (Nm)/(ft lb) | | (If no specific torque is stipulated, check that all bolts of a joint are tightened equally.) | |
|--------------------------------|---------|---|---------|
| Engine mounting | 90/66 | Transmission pump | 81/59 |
| Rear axle suspension | 434/320 | Vibrator pump | 38/28 |
| Flywheel cover | 50/36 | Wheel nuts | 550/405 |
| Pump drive | 50/36 | Rubber elements | 90/66 |

| Weight (kg/lb) and dimensions (mm/inch) | CA 251 | | PD | CA 301 | |
|--|---------------|---------------|----------------|----------------|----------------|
| | Std | D | | Std | D |
| Weight, standard equipped roller | 9300 20500 | 9500 20900 | 10900 24000 | 11100 24450 | 11800 26000 |
| Length, standard equipped roller | 5380 212 | 5380 212 | 5520 217 | 5380 212 | 5380 212 |
| Width, standard equipped roller | 2370 93 | 2550 100 | 2550 100 | 2400 94 | 2580 102 |
| Height, standard equipped roller | 2200 87 | 2200 87 | 2250 89 | 2200 87 | 2200 87 |
| Height, standard equipped roller with cab | 2800 110 | 2800 110 | 2850 112 | 2800 110 | 2800 110 |

| Volumes (litres/quarts, gallons) | |
|--|--|
| Rear axle, differential planetary gears | 10,5 l/11 qts 2,5 l/2.64 qts (each) |
| Fuel tank | 265 l/70 gal |
| Diesel engine Cummins, oil | 16 l/17 qts |
| Cummins , coolant | 27 l/28 qts |
| Deutz, oil | 14 l/15 qts |
| Hydraulic system, reservoir | 175 l/ 46 gal |
| Pump drive | 1,5 l/1.6 qts |
| Drum, vibrator unit | 2 x 26,5 l/2 x 28 qts |
| Drum drive Torque hub | 3 l/3 qts |

| Wheel drive | |
|----------------------------|--|
| Tire size Tire pressure | 23.1 x 26 x 8 ply 0.11-0.15 MPa/16-21 psi |

| Electrical system | |
|-------------------|-------------------|
| Battery Fuses | 12 V 160 Ah 8A |

MAINTENANCE SCHEDULE

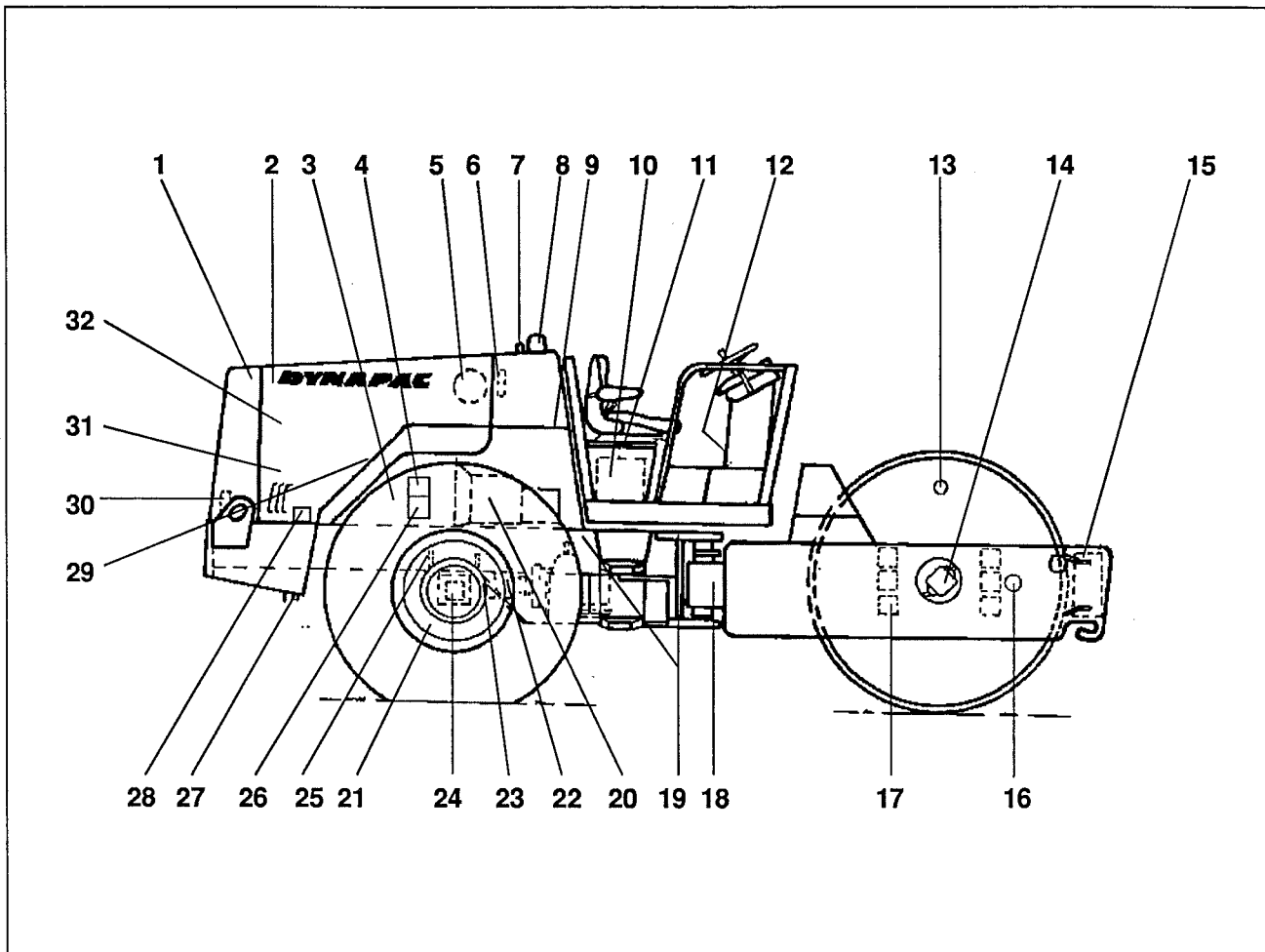

Fig. 1 Service points

- | | | |
|------------------------------------|--|-------------------------------------|
| 1 Coolant | 14 Torque hub | 25 Rear axle suspension, two sides |
| 2 Engine hood, hinges | 15 Scraper | 26 Oil filter, diesel engine |
| 3 Oil level, engine | 16 Drum oil, sight glass, two | 27 Drain, fuel tank |
| 4 Fuel filter | 17 Rubber elements and fastening bolts | 28 Engine suspension, four |
| 5 Air cleaner | 18 Articulated steering | 29 Supply pump, fuel |
| 6 Hydraulic reservoir, sight glass | 19 Steering cylinders, two | 30 Diesel fuel, filling |
| 7 Venting filter | 20 Flywheel cover, hydraulic pumps | 31 Hydraulic fluid cooler* |
| 8 Hydraulic filter, two | 21 Wheel nuts | 32 Drive belts, cooling, alternator |
| 9 Drain, hydraulic reservoir | 22 Tyres, pressure | |
| 10 Battery | 23 Rear axle, differential | |
| 11 Hydraulic reservoir, filling | 24 Rear axle, planetary gears, two | |
| 12 Fuse box | | |
| 13 Drum oil, filling, two | | |

* Cooler diesel engine hydraulic fluid

MAINTENANCE MEASURES

Periodical servicing items must be carried out at the time they are first indicated, i.e., each day, each week, etc., or on completion of the number of operating hours stated.

CAUTION



Always clean off the surrounding dirt before draining, filling or checking oil and fuel, and before lubricating with oil or grease.

Daily (Every 10 hours of operation)

| Item in Fig. 1 | Measure | See page | Note |
|----------------|---|----------|-------------------|
| | Before first start | | |
| 3 | Check level of engine oil | | See engine manual |
| 1 | Check coolant level, Cummins | 10 | |
| 31 | Check circulation of air in the radiator, Cummins | | |
| 15 | Check scraper setting | 10 | |
| 4 | Drain the water trap, Cummins | | See engine manual |
| | On completion of the shift | | |
| 6 | Check level of hydraulic reservoir | 11 | |
| | Drain and refill new oil if needed | | |
| 30 | Fill the fuel tank | 11 | |

Weekly (Every 50 hours of operation)

| Item in Fig. 1 | Measure | See page | Note |
|----------------|---|----------|-----------------------------------|
| 26 | Change engine oil and oil filter | | New comp. only, see engine manual |
| 5 | Clean air filter insert. Ensure that hoses and connections are tight. | 12 | |
| 10 | Check the battery | 13 | |
| 18 | Lubricate the steering joints | 14 | |
| 19 | Lubricate the steering cylinder brackets | 14 | |
| 17 | Check the rubber elements and bolts | 15 | |
| 14 | Change oil in the torque hub (D and PD) | | New comp. only |
| 21 | Check tightening torque, wheel nuts | 15 | |
| 22 | Check tyre pressure | 15 | |

MAINTENANCE SCHEDULE

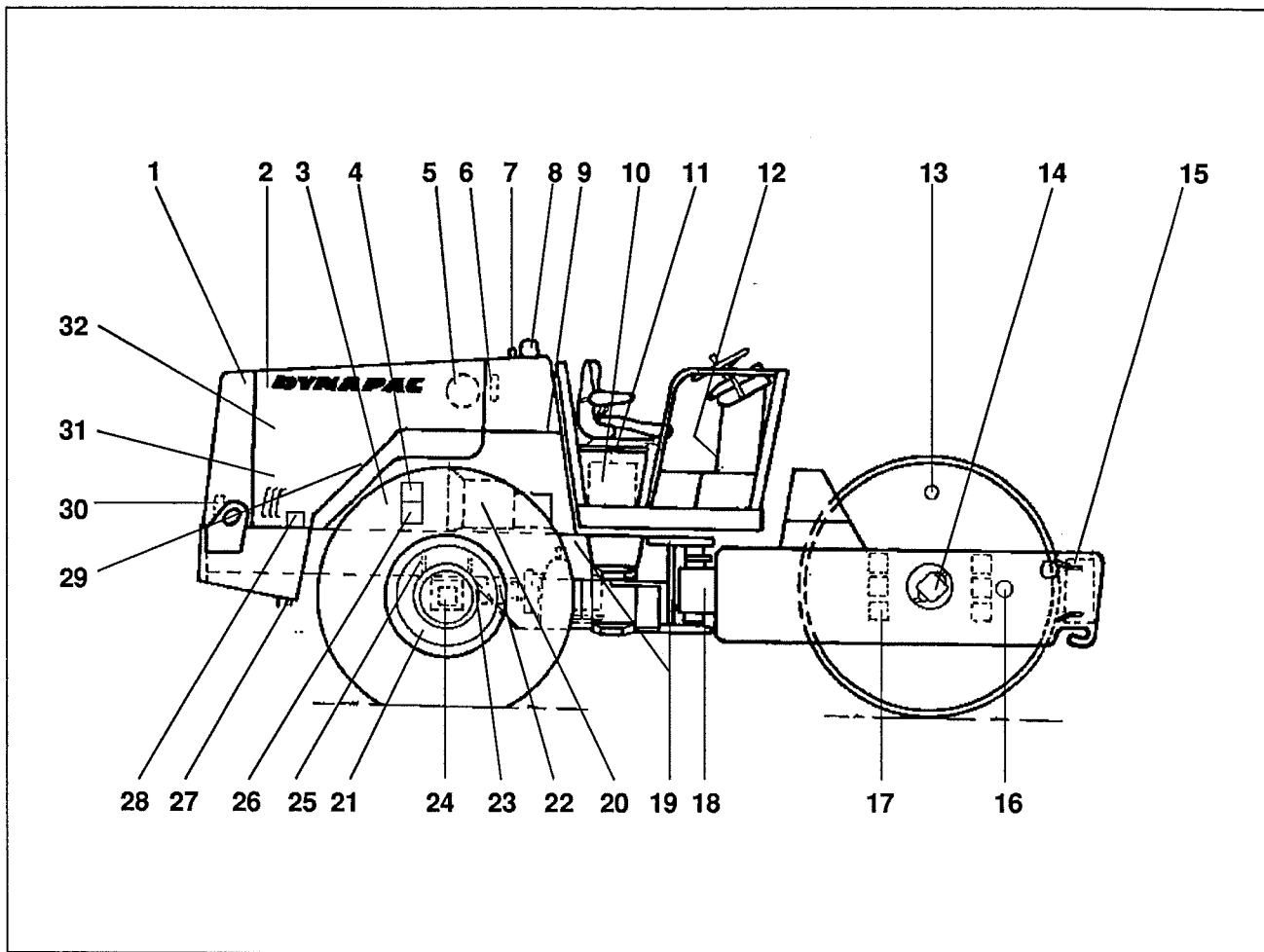

Fig. 1 Service points

- | | | |
|------------------------------------|--|-------------------------------------|
| 1 Coolant | 14 Torque hub | 25 Rear axle suspension, two sides |
| 2 Engine hood, hinges | 15 Scraper | 26 Oil filter, diesel engine |
| 3 Oil level, engine | 16 Drum oil, sight glass, two | 27 Drain, fuel tank |
| 4 Fuel filter | 17 Rubber elements and fastening bolts | 28 Engine suspension, four |
| 5 Air cleaner | 18 Articulated steering | 29 Supply pump, fuel |
| 6 Hydraulic reservoir, sight glass | 19 Steering cylinders, two | 30 Diesel fuel, filling |
| 7 Venting filter | 20 Flywheel cover, hydraulic pumps | 31 Hydraulic fluid cooler* |
| 8 Hydraulic filter, two | 21 Wheel nuts | 32 Drive belts, cooling, alternator |
| 9 Drain, hydraulic reservoir | 22 Tires, pressure | |
| 10 Battery | 23 Rear axle, differential | |
| 11 Hydraulic reservoir, filling | 24 Rear axle, planetary gears, two | |
| 12 Fuse box | | |
| 13 Drum oil, filling, two | | |

* Cooler diesel engine hydraulic fluid

Monthly (Every 250 hours of operation)

| Item in Fig. 1 | Measure | See page | Note |
|----------------|---|----------|-------------------|
| | Clean the engine cooling fins | | See engine manual |
| 32 | Check the belt-tension monitor, Deutz | | ---- " ---- |
| 32 | Check belt tension on fan and alternator | | ---- " ---- |
| 26 | Change engine oil and filter | | ---- " ---- |
| 8 | Change hydraulic fluid filter | 16 | |
| 31 | Clean outside of hydraulic fluid cooler | 16 | |
| 14 | Check oil level in torque hubs | 17 | |
| 16 | Check oil level in drum | 17 | |
| 23, 24 | Check oil level in rear axle/ planetary gears | 18 | |
| 2 | Lubricate controls and moving joints | 17 | |
| 20, 28 | Check tightening torque of bolted joints | 19 | |
| 20 | Check oil level in pump drive | 19 | |

Every six months (Every 1000 hours of operation)

| Item in Fig. 1 | Measure | See page | Note |
|----------------|--|----------|-------------------|
| 9 | Drain condensed water from the hydraulic reservoir | 20 | |
| 7 | Change venting filter in hydraulic reservoir | 20 | |
| 27 | Drain condensed water from the fuel tank | 20 | |
| 14 | Change oil in torque hubs (D and PD only) | 21 | |
| 4 | Change the fuel filter | | See engine manual |
| 29 | Change the fuel strainer, Deutz | | ---- " ---- |
| | Check the valve clearance | | ---- " ---- |
| | Change the pre-filter | | |

Yearly (Every 2000 hours of operation)

| Item in Fig. 1 | Measure | See page | Note |
|----------------|--|----------|------|
| 9 | Clean inside of reservoir and change the fluid | 22 | |
| 20 | Change oil in pump drive | 22 | |
| 13, 16 | Change drum oil | 23 | |
| 23 | Change oil in the rear axle planetary gears | 24 | |
| 24 | Change oil in the rear axle differential | 24 | |

DAILY (Every 10 hours of operation)

Coolant level - checking, filling

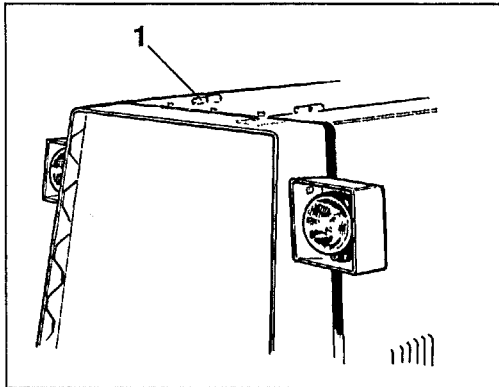

Fig. 2 Radiator
1 Filler cap

WARNING



TAKE GREAT CARE WHEN OPENING THE RADIATOR FILLER CAP WHEN THE ENGINE IS WARM. THE COOLANT IS UNDER PRESSURE WHICH IMPLIES THE RISK OF SCALDING BY HIGH-TEMPERATURE STEAM. WEAR PROTECTIVE GLOVES AND GOGGLES.

See engine maintenance instructions. Fill with coolant noted on page 3.

CAUTION



Drain, flush the system and fill with fresh coolant every other year. Make sure that air can flow freely through the radiator.

Scrapers - checking, adjustment

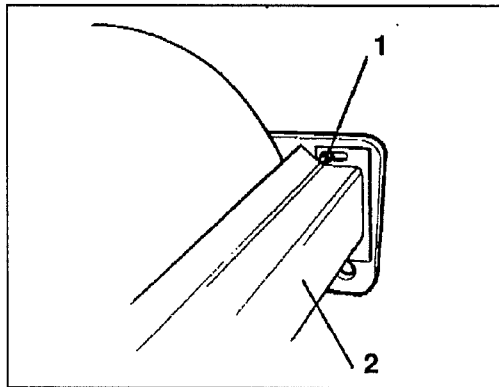

Fig. 3 Front scraper
1 Fastening bolts
2 Scraper

Adjust the gap as follows:

1. Loosen all four fastening bolts.
2. Set the scraper about 15 mm (0.6") from the drum.
3. Tighten the bolts.

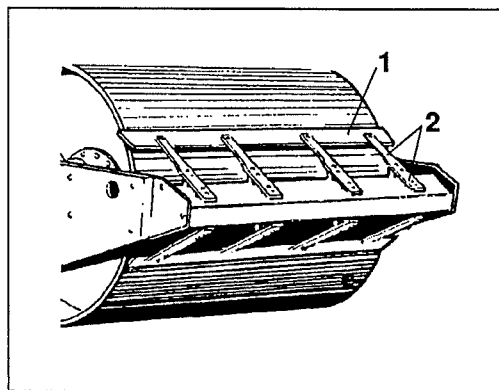

Fig. 4
1 Scraper blade
2 Fastening bolts

Heavy scraper

1. Loosen the four fastening bolts on half of the scraper blade.
2. Set the scraper blade about 15 mm (0.6") from the drum. Tighten the bolts.
3. Adjust the other three scraper blade sections to the same gap.

Hydraulic reservoir - checking the fluid level

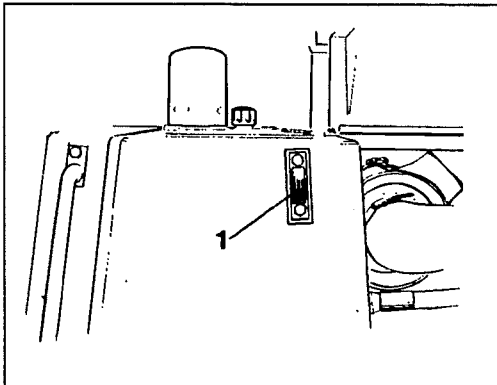

Fig. 5 Hydraulic reservoir
1 Sight glass

1. Position the roller on a level surface and check the sight glass reading.
2. Top up with recommended hydraulic fluid if the level is 20 mm (0.8") or more below the upper edge of the glass.

Hydraulic reservoir - filling

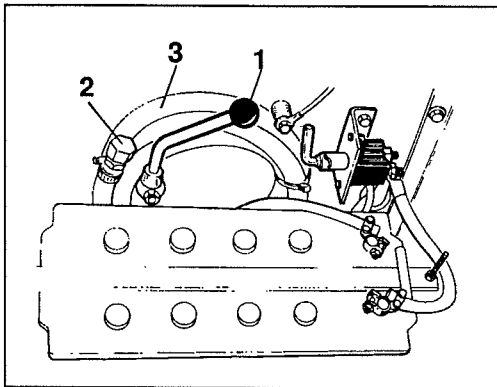

Fig. 6 Filling pump
1 Hand pump
2 Protective plug
3 Suction hose

3. Take out the suction hose from the battery box.
4. Clean the hose and screw off the protective plug.
5. Insert the hose into a drum of clean hydraulic fluid.
6. Pump with the lever and fill the reservoir to the mark on the sight glass. Hydraulic fluid is pumped via a filter to the reservoir so it is necessary to always refill with clean fluid in this way.

Fuel tank - filling

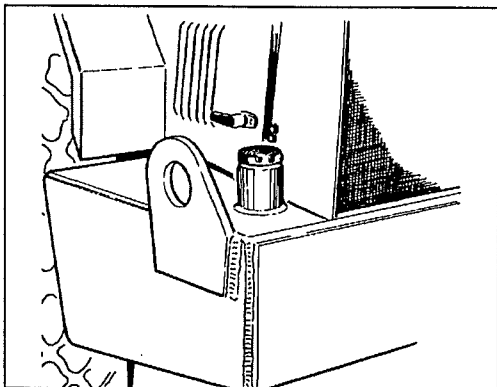

Fig. 7 Fuel tank

Refuel with diesel fuel up to the lower edge of the filler pipe daily at the end of operations.

WARNING



STOP THE ENGINE. SHORT CIRCUIT THE FILLER NOZZLE AGAINST A NON-INSULATED PART OF THE MACHINE BEFORE STARTING TO REFUEL.

(See the respective engine manufacturer's instructions with regard to quality of diesel fuel.)

WEEKLY (Every 50 hours of operation)

Air cleaner - cleaning the main filter element

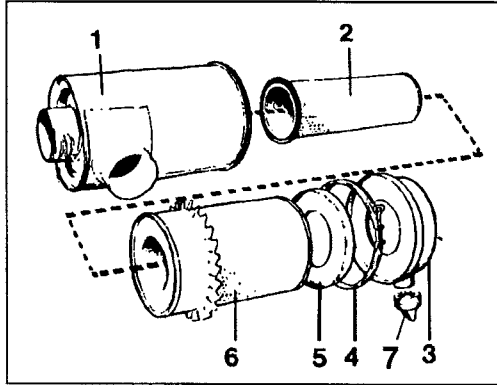

Fig. 8 Air cleaner

- 1 Filter housing
- 2 Backup filter
- 3 Vacuator valve
- 4 Clip
- 5 Inner cover
- 6 Main filter
- 7 Vacuator valve

Main filter - Cleaning with compressed air/by washing

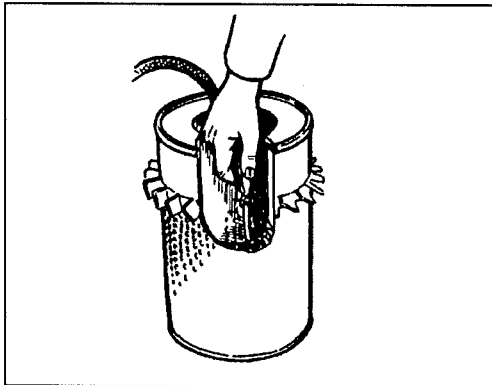

Fig. 9 Main filter

1. Loosen the clip and take off.
2. Screw off the wing nut at the centre of the filter and take off the inner cover. Clean with a clean rag.
3. Screw off the wing nut and pull out the main filter.
4. Make sure that dust has not penetrated the main filter during operation.
5. Wipe the inside of the filter housing and intake pipes with a clean rag.
6. Check that hoses and connections between the filter housing and engine are intact and tight.
7. Clean the emptying slits of the vacuator valve.

CAUTION



Replace the backup filter with a new one every third time the main filter is changed or cleaned. The backup filter cannot be cleaned and reused.

Use compressed air at a maximum pressure of 0.7 MPa (100 psi).

Blow up and down along the paper folds on the inside of the filter element. Hold the nozzle at least 10 mm (0.4") from the folds to avoid tearing the paper.

If the filter is sooty or oily it should be rinsed in a solution of water and non-lathering detergent, e.g., "Donaldson D-1400".

Allow the element to soak fully immersed in the solution for at least 15 minutes. Lift the element up and down several times while soaking to improve the washing effect.

Ensure that the filter element is intact before refitting. The element must be replaced if there are holes in the paper or if the seals are damaged. Hold the filter against a light to check.

CAUTION



A filter element that has been washed in detergent must be completely dry before refitting.

Battery - checking the electrolyte level

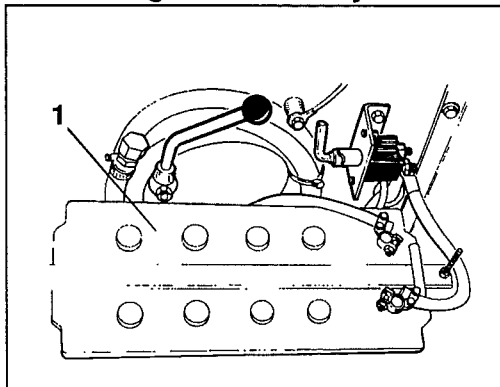

Fig. 10 Battery box
1 Battery

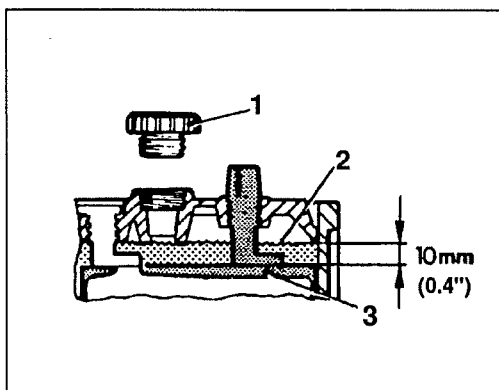

Fig. 11 Electrolyte level in battery
1 Cell cap
2 Electrolyte level
3 Plate

WARNING



NEVER USE A NAKED FLAME WHEN CHECKING THE BATTERY. THE ELECTROLYTE EMITS EXPLOSIVE GAS WHILE THE ALTERNATOR IS CHARGING.

1. Lift the seat.
2. Wipe the top of the battery.

3. Take off the cell caps and check that electrolyte level is about 10 mm (0.4") above the plates.

Check the level of all cells. Top up with distilled water as required to the correct level.

If ambient temperature is below zero, the engine should be run for a while after topping up with distilled water, i.e., there is otherwise a risk that the battery fluid will freeze.

4. Make sure the venting holes in the cell caps are not clogged. Refit the caps.
5. Battery terminals must be clean and well tightened. Clean corroded terminals and grease them with acid-free Vaseline.

WEEKLY (Every 50 hours of operation), contd.

Articulated steering, steering cylinders - lubrication

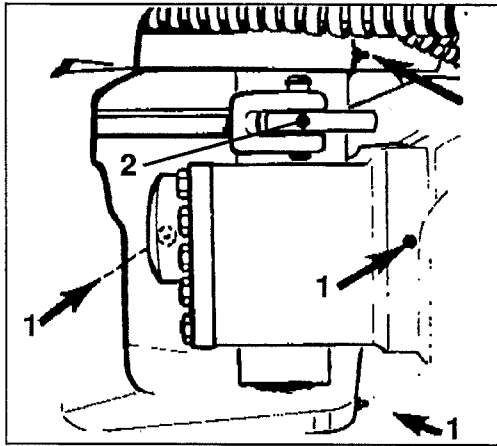

Fig. 12 Steering, right side
1 Nipples, articulated steering
2 Nipples, steering cylinder

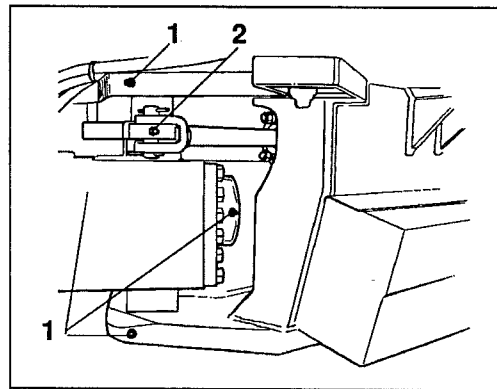

Fig. 13 Steering, left side
1 Nipples, articulated steering
2 Nipples, steering cylinder

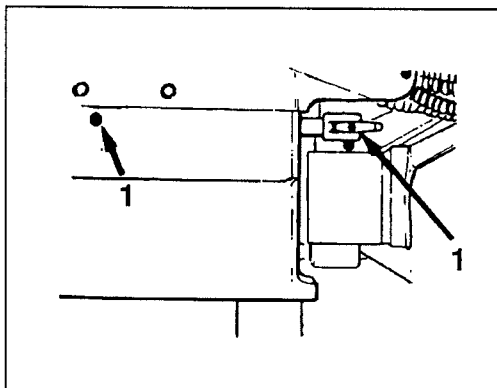

Fig. 14 Steering cylinders
1 Lubricating nipples

WARNING



RISK OF INJURY. KEEP EVERYONE CLEAR OF THE ARTICULATED STEERING MECHANISM WHILE THE ENGINE IS RUNNING.

1. Turn the drum to the left to provide access to all lubricating nipples of the steering joint (on right side).
2. Wipe all six nipples clean from dirt and grease.
3. Lubricate each nipple (1) with five strokes and each nipple (2) with two strokes of the grease gun. Make sure that grease penetrates the bearings.

4. Turn the drum to the right and lubricate nipples (1) and (2) in the same way on the left side.

Use grease recommended on page 3.

Leave a little grease on the nipples after greasing. This will prevent dirt from entering the nipples.

It may be necessary to relieve load from the articulated joint with a jack and repeat the greasing procedure if grease does not penetrate the bearings.

Rubber elements and fastening bolts - inspection

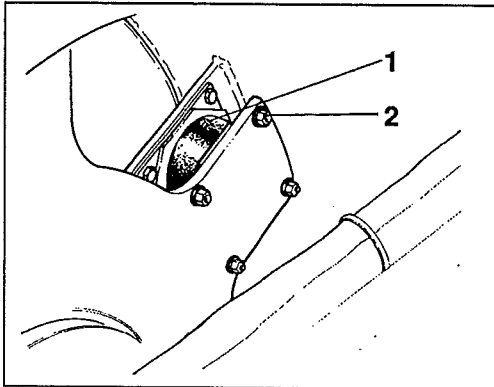

Fig. 15 Drum
1 Rubber element
2 Fastening bolts

Make sure that the rubber elements are undamaged and that the mounting bolts are tight. Replace the elements if cracks are deeper than 10 to 15 mm (0.4" - 0.6").

Use a knife blade or similar object to assist in measuring the depth of cracks.

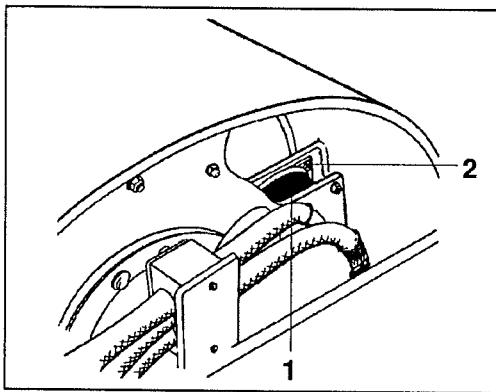

Fig. 16 Drum
1 Rubber element
2 Fastening bolts

Make the same check of rubber elements on the drive side.

Tyre pressure Wheel nuts - tightening

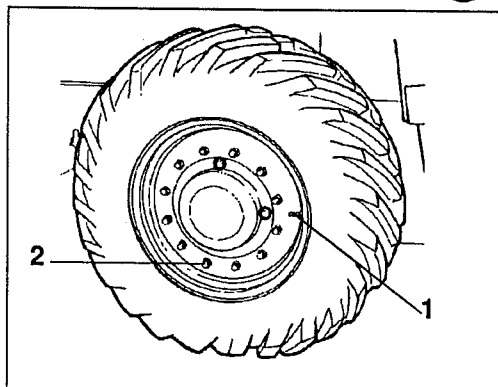

Fig. 17 Wheel
1 Air valve
2 Wheel nut

Check the tyres with a pressure gauge.

Minimum tyre pressure 0.11 MPa (16 psi).
Maximum tyre pressure 0.15 MPa (22 psi).

CAUTION



Check both tyres. When changing tyres it is essential that they both have the same rolling radius. See relevant Parts Information.

Check tightening torque of the wheel nuts at 550 Nm (405 ft.lb). Check all nuts on both wheels.

MONTHLY (Every 250 hours of operation)

Hydraulic fluid cooler - external cleaning

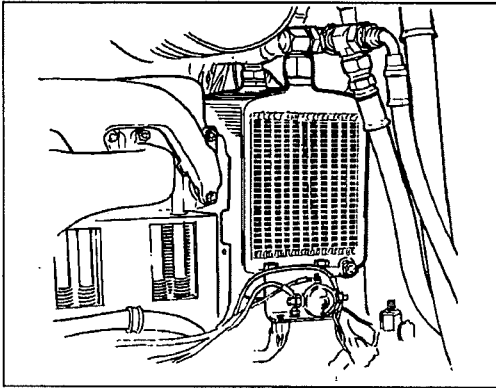

Fig. 18 Hydraulic fluid cooler

Ensure that air can flow freely through the cooler cells without obstruction. A dirty cooler should be cleaned with water or compressed air.

Cover electrical components and then flush or blow the cooler clean in the opposite direction to the normal flow of air.

Ensure after cleaning that seals and noise absorbers are undamaged.

Hydraulic fluid filter - changing

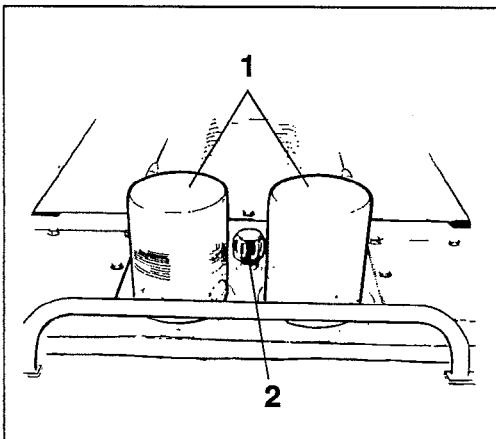

Fig. 19 Hydraulic reservoir
1 Hydraulic filter
2 Venting filter

1. Loosen the venting filter to release any over-pressure in the reservoir.
2. Remove the hydraulic filters, empty fluid from the filters into the spill oil container and discard the filters.

CAUTION



Ensure that the previous sealing rings are removed. Leakage will otherwise occur between the old and new sealing rings.

3. Thoroughly clean the sealing surfaces of the filter holders.
4. Apply a thin coat of hydraulic fluid to the sealing ring of the new filters.
5. Screw on the filters firmly by hand. I.e., screw on until the seal makes contact with the seating and then screw half a turn further.

CAUTION



Do not tighten too hard, the seal may otherwise be damaged.

6. Start the engine and check for any leakage from the filters.

Torque hub - checking the oil level

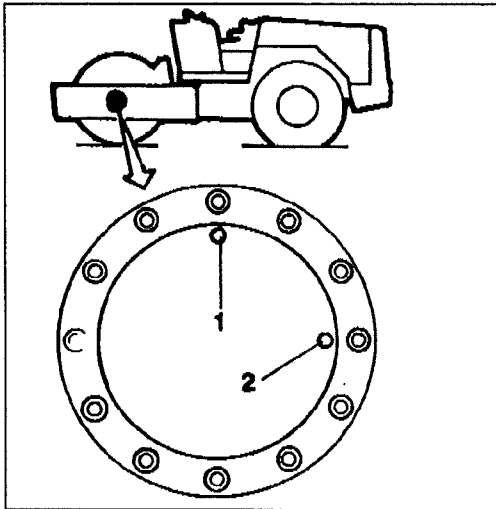

Fig. 20 Filling with oil
1 Filler plug
2 Level/drain plug

Applies to D and PD only:

1. Position the roller on a level surface, with the filler plug at the top.
2. Wipe clean around the plugs.
3. Remove the plugs and check that oil reaches up to the level plug.
4. Top up with gear lubricant as required, see page 3.

Drum - checking the oil level

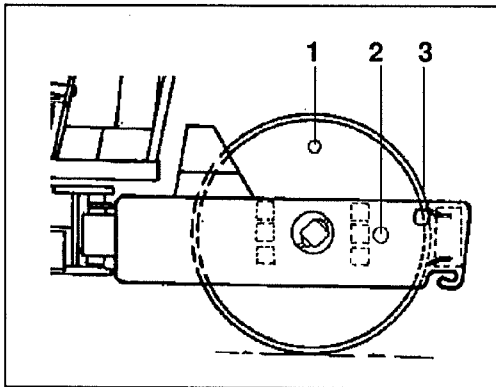

Fig. 21 Checking the oil level
1 Filling
2 Sight glass
3 Sight bar (later models)

1. Position the roller on a level surface, with the filler plug at the top. The sight bar should be in line with the top of the frame beam when the plug is straight up.
2. Check that oil reaches about half way up the sight glass.
3. Top up with gear lubricant as required but not more than half way up the sight glass.
4. Repeat items 1-3 on the other side of the drum.

Controls and moving joints - lubrication



Lubricate the engine hood hinges with a grease gun and the controls and other moving joints with oil.

MONTHLY (Every 250 hours of operation), contd.

Rear axle differential - checking the oil level

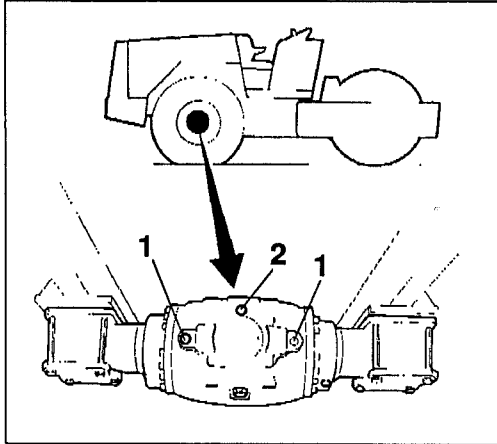

Fig. 22 Level check - differential housing
1 Level plug
2 Filler plug

WARNING



NEVER WORK UNDER THE MACHINE WHILE THE ENGINE IS RUNNING. ALWAYS PARK ON A LEVEL SURFACE AND CHOCK THE WHEELS.

1. Make sure the roller is level.
2. Unscrew the level plugs and check that oil level is up to the lower edge of the plug hole. Top up with oil through the filler plug as required to the correct level. Use gear lubricant.

Rear axle planetary gearing - checking the oil level

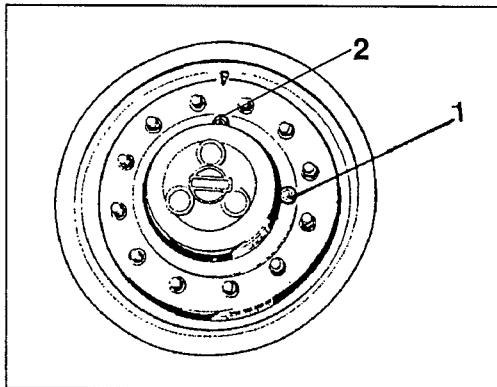

Fig. 23 Level check - planetary gearing
1 Level plug
2 Filler plug

1. Position the roller on a level surface with one plug of the planetary gearing at the top, the other will then be horizontal.
2. Unscrew plug and check that oil level is up to the lower edge of the plug hole. Top up with oil through the filler plug as required to the correct level. Use gear lubricant.
3. Check the oil level of the other planetary gearing of the rear axle in the same way.

Tightening check - bolted joints

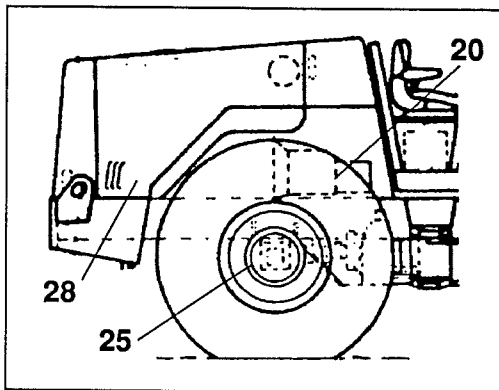

Fig. 24 Bolted joints
20 Pumps
25 Rear axle
28 Engine

1. Rear axle suspension (25) 434 Nm (320 ft.lb).
2. Control pump against propulsion pump (20) 38 Nm (28 ft.lb).
3. Engine suspension (28). Ensure that all bolts are tightened.

Pump drive - checking the oil level

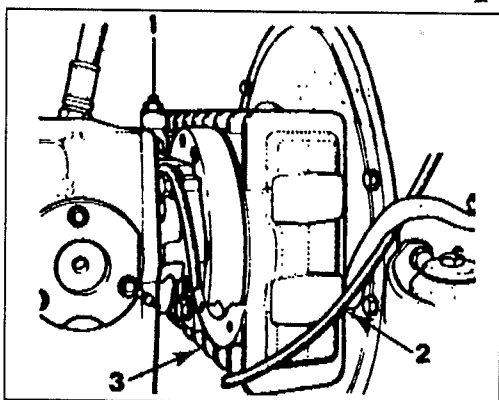

Fig. 25 Level check
1 Filler plug
2 Level plug
3 Drain plug

1. Make sure the roller is standing level.
2. Loosen the level plug a few turns and oil should seep out.
3. Top up as required through the filler hole. Check the level on one side only.

EVERY SIX MONTHS (Every 1000 hours of operation)

Hydraulic reservoir - draining

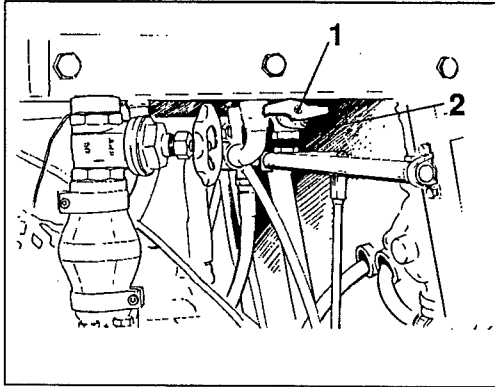

Fig. 26 Hydraulic reservoir
1 Drain cock
2 Plug

Drain off condensed water from the hydraulic reservoir via the cock (1). Drain after the roller has stood still for a longer period, e.g., overnight.

Drain as follows:

1. Hold a can underneath the cock.
2. Remove the plug.
3. Open the cock and allow any water to run out.
4. Close the drain cock.
5. Refit the plug.

Hydraulic reservoir - venting filter

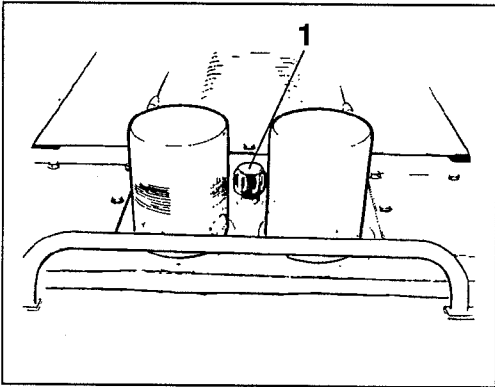

Fig. 27 Hydraulic reservoir
- changing the venting filter
1 Venting filter

1. Screw out the venting filter (1) and discard it.
2. Fit a new filter.

Fuel tank - draining

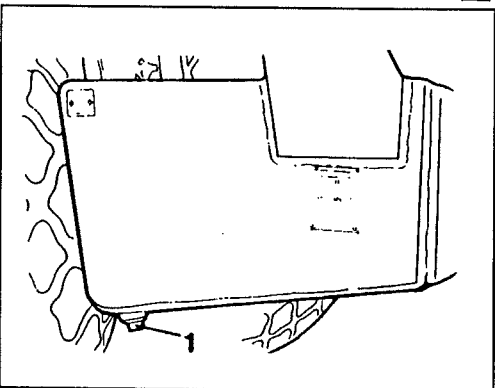

Fig. 28 Fuel tank
1 Drain plug

Drain off condensed water and sediment from the fuel tank via the drain plug.

CAUTION



Be very careful not to drop the plug which would allow all the fuel to run out.

Drain after the roller has stood still for a longer period, e.g., overnight. The roller should preferably stand at a slight angle so that water and sediment is concentrated above the drain plug.

Drain as follows:

1. Hold a can underneath the plug.
2. Loosen the plug carefully and allow water and sediment to run out.
3. Tighten the plug.

Torque hub - changing the oil

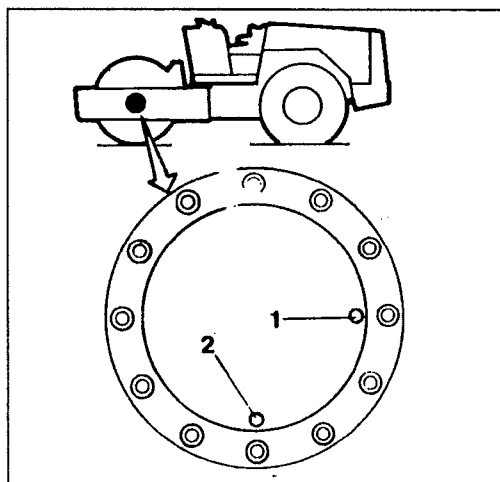

Fig. 29 Draining the oil
1 Filler plug
2 Drain/level plug

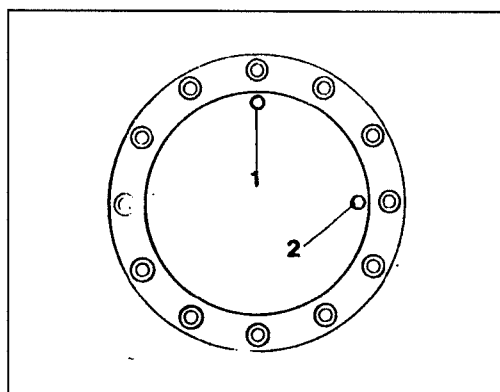

Fig. 30 Filling the oil
1 Filler plug
2 Drain/level plug

CAUTION



Before changing oil it is essential that the machine is run long enough to make the oil warm and easy flowing. Any impurities present will then come out with the oil. Observe cleanliness and make sure the roller is level.

Applies to D and PD only:

1. Position the roller on a level surface with the drain/level plug at the bottom.
2. Wipe clean around the plugs.
3. Place a can under the drain plug and drain off the oil. The can should hold about 3 litres (3 qts). Remove the filler plug also.
4. Reverse the roller until the filler plug is at the top.
5. Fill with oil through up to the level plug. Use transmission oil, see page 3. Amount of oil about 3 litres (3 qts).
6. Fit the plugs back again.

YEARLY (Every 2000 hours of operation)

Hydraulic reservoir - changing the fluid

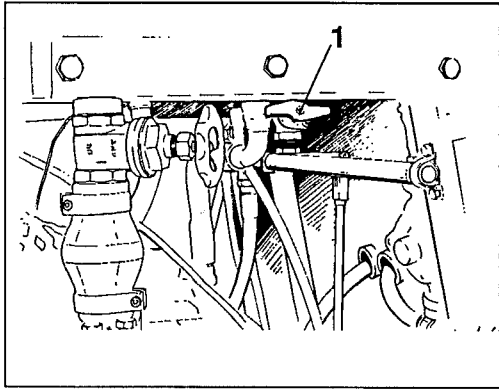

Fig. 31 Emptying the hydraulic reservoir
1 Drain cock

1. Place a suitable receptacle for at least 200 litres (53 gal) at the side of the machine, e.g., an empty oil drum. Connect a hose to the drain cock and empty the contents of the reservoir into the receptacle.
2. Fill the reservoir with hydraulic fluid, in accordance with the instructions on page 11.
3. Change the hydraulic filters.
4. Start the engine and run the various hydraulic functions.
5. Check the fluid level and top up if necessary.

Pump drive - changing the oil

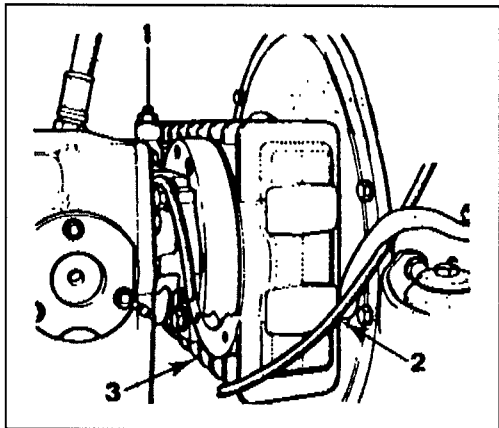

Fig. 32 Transfer gearbox
1 Filler plug
2 Level plug
3 Drain plug

WARNING



NEVER WORK UNDER THE MACHINE WHILE THE ENGINE IS RUNNING. PARK ON A LEVEL SURFACE. CHOCK THE DRUM AND WHEELS.

1. Loosen the drain plug and drain off the oil.
2. Refit the plug.
3. Remove the level plug and fill with fresh gearbox oil through the filler hole. Fill slowly to allow the oil to level out.
4. Fit the filler and level plugs back again at the right oil level.

Drum - changing the oil

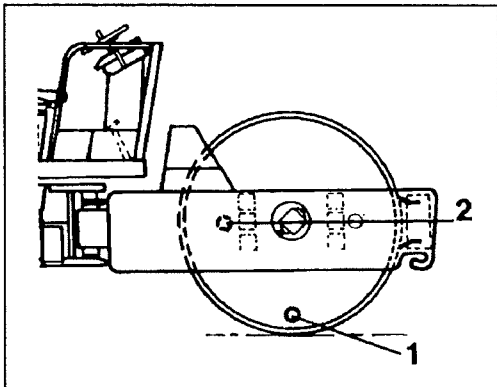

Fig. 33 Draining the oil
1 Drain/filler plug
2 Sight glass

1. Run the roller until the drain/filler plugs are straight down. Loosen the plug on one side and drain off the oil.
2. Drain oil on the other side.

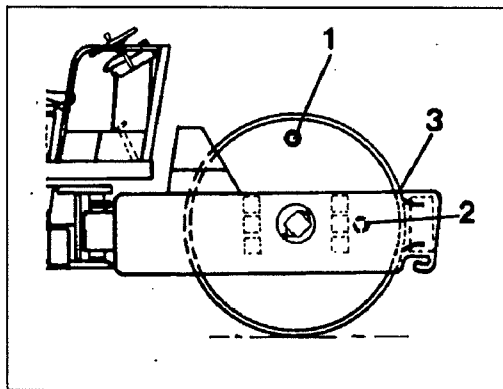

Fig. 34 Filling with oil
1 Filler/drain plug
2 Sight glass
3 Dipstick

3. Run the roller until the plugs are straight up, the dipstick level with the roller frame.
4. Fill with the required amount of gear lubricant. Check that the oil reaches about half way up the sight glass.

YEARLY (Every 2000 hours of operation), contd.

Rear axle planetary gearing - changing the oil

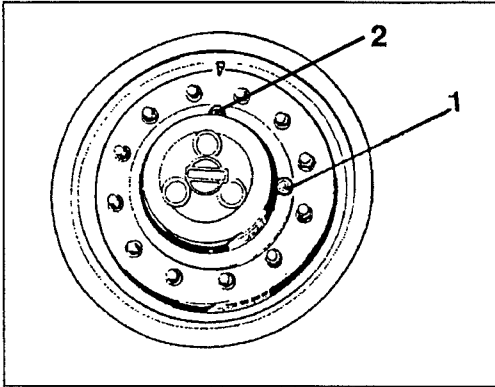

Fig. 35 Planetary gearing
1 Level plug
2 Filler/Drain plug

1. Position the roller on a level surface with one of the plugs straight down.
2. Unscrew this plug and drain off the oil into a can. Loosen the other plug to speed up the flow of oil.
3. Run the roller to position one of the plugs at the top and the other horizontally.
4. Fill with oil, see page 3, through the upper hole until it runs out at the lower hole.
5. Refit the plugs and repeat the procedure in the same way on the other side.

Rear axle differential - changing the oil

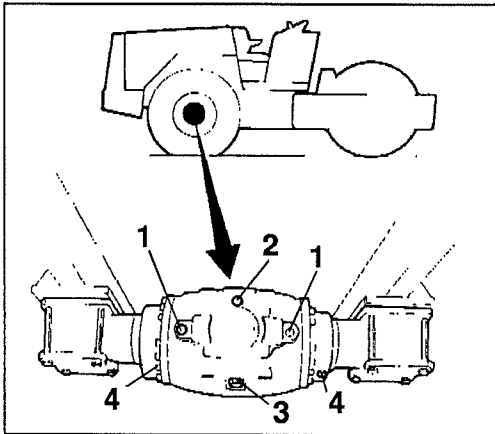

Fig. 36
1 Level plug
2 Filler plug
3 Drain plugs
4 Drain plug

1. Position the roller level.
2. Remove one of the drain plugs and empty the oil into a can. Also remove filler plug and one of the level plugs.
3. Refit plug and fill with oil, see page 3, up to the correct level.
4. Refit plugs.

SPECIAL INSTRUCTIONS

**Higher ambient temperature,
maximum +50°C (122°F)**

On leaving the factory the various systems and components are filled with oil or fluid as indicated on page 3 and are thus suitable for operation in ambient temperatures between -10°C and +40°C (14°F - 104 °F).

The engine can be used at this temperature using normal oil but for other components the following oils must be used:

| | |
|---|--|
| Hydraulic system: | Shell Tellus Oil T100, or equivalent. |
| Other components using transmission oil: | Shell Spirax HD 85W/140 or equivalent. |

Lower ambient temperature

Contact Dynapac.

Temperature limits apply to standard versions of the roller.

ELECTRICAL SYSTEM

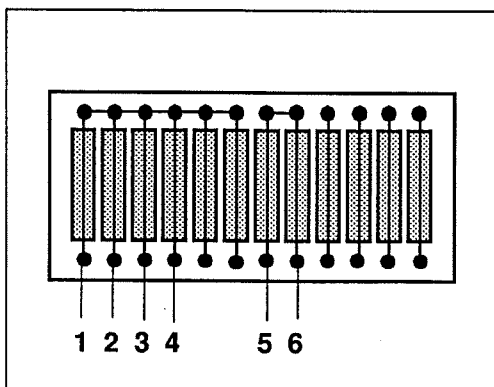

Fig. 37 Fuse box

1. Lights
2. Horn
3. Sprinkler pumps
4. Instrument and warning lamps
5. Speedometer and frequency meter
6. Vibrator system

The machine is equipped with a 12 V power supply and alternator.

WARNING



CONNECT THE BATTERY WITH THE CORRECT POLARITY. THE CABLE BETWEEN THE BATTERY AND ALTERNATOR MUST NOT BE REMOVED WHILE THE ENGINE IS RUNNING.

WARNING



BEFORE STARTING ANY ELECTRIC WELDING ON THE MACHINE, DISCONNECT THE BATTERY GROUND CABLE AND THEN OTHER CONNECTIONS TO THE ALTERNATOR.

The electrical regulating and control system is fitted with 8 A fuses located in the fuse box.

Figure indicates the function of the various fuses.

